

(No Model.)

3 Sheets—Sheet 1.

E. E. CARTER.

REMOVABLE VALVE COVER.

No. 277,227.

Patented May 8, 1883.

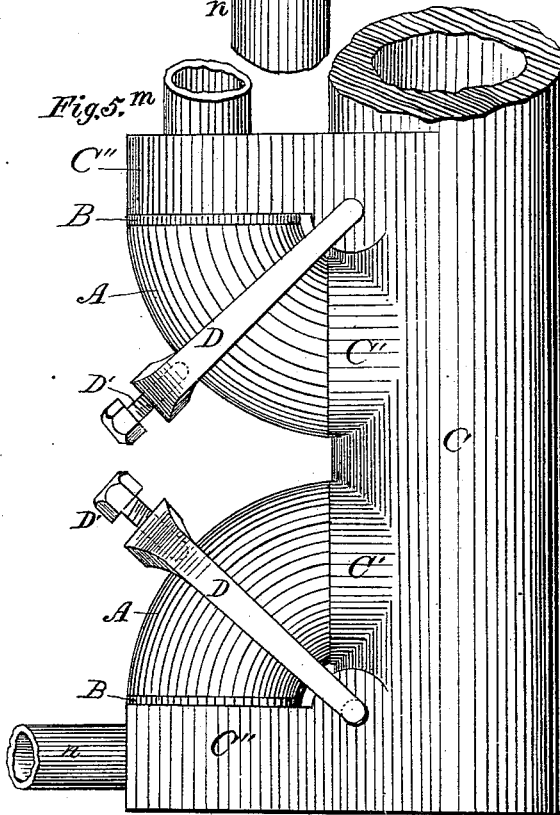
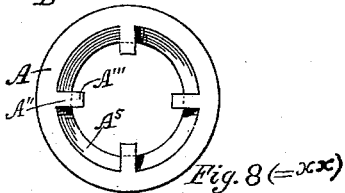
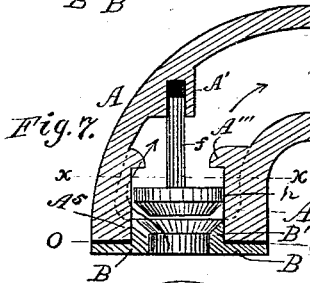
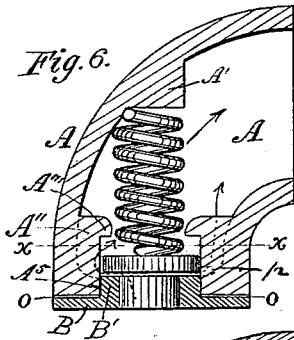
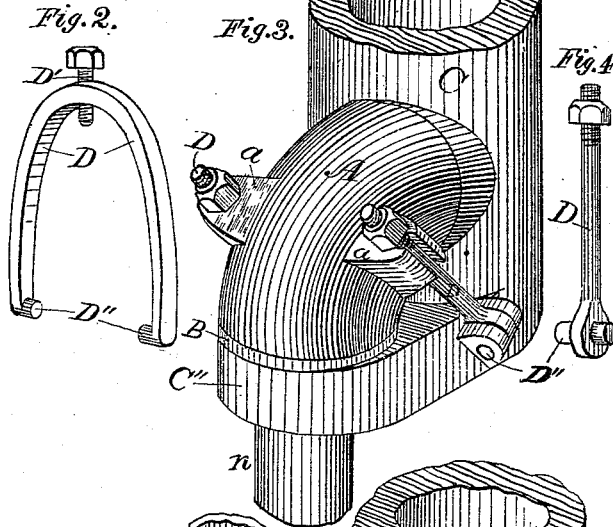
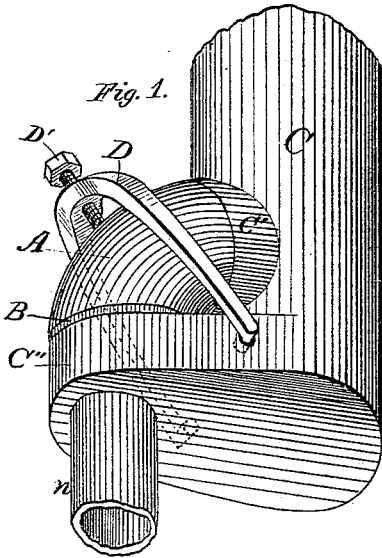

Witnesses:
J. C. Guiber
John M. Wallace

Inventor:
Edwin E. Carter

E. E. CARTER.

REMOVABLE VALVE COVER.

No. 277,227.

Patented May 8, 1883.

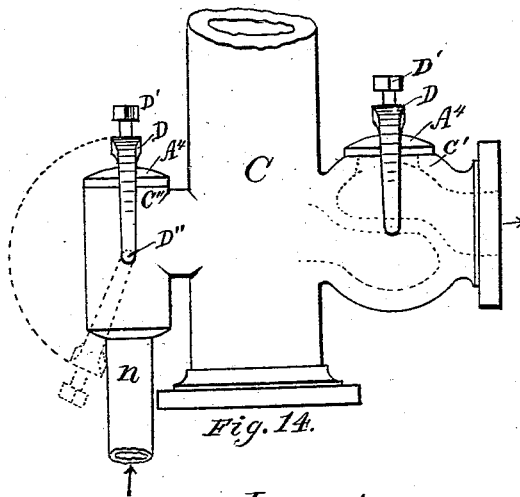
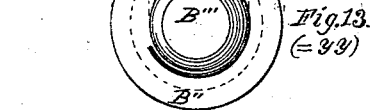
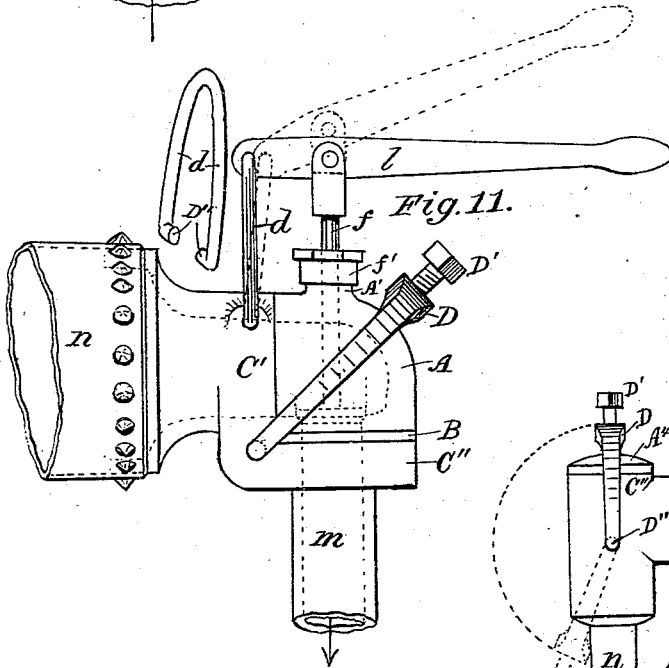
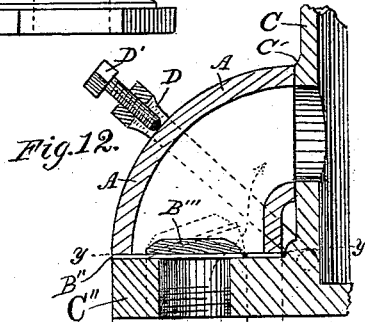
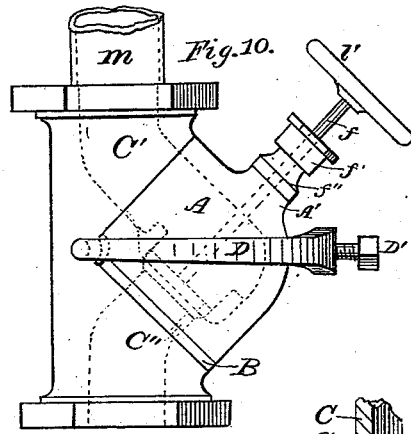
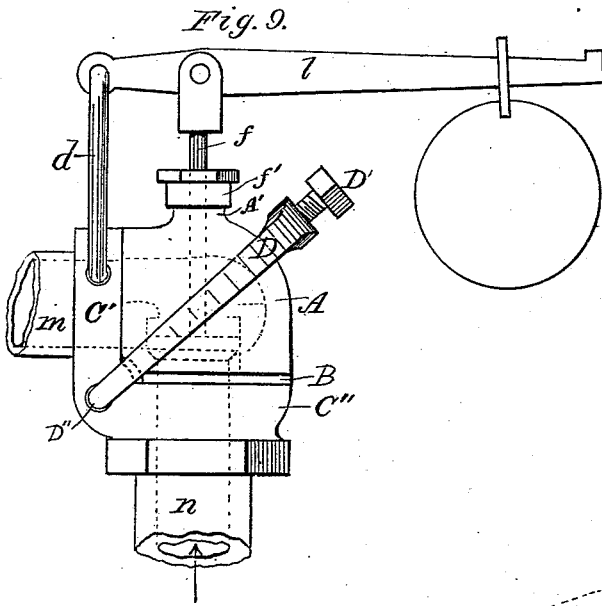

Witnesses:
F. S. Guiker
John M. Wallace

Inventor:
Edwin E. Carter

UNITED STATES PATENT OFFICE.

EDWIN E. CARTER, OF WAYNESBURG, PENNSYLVANIA, ASSIGNOR TO S. E. CARTER, OF SAME PLACE.

REMOVABLE VALVE-COVER.

SPECIFICATION forming part of Letters Patent No. 277,227, dated May 8, 1883.

Application filed June 24, 1882. (No model.)

To all whom it may concern:

Be it known that I, EDWIN E. CARTER, a citizen of the United States, residing at Waynesburg, in the county of Greene and State of Pennsylvania, have invented a new and useful Removable Valve-Cover, of which the following is a specification.

The object of my invention is to provide a valve-cover that shall be more readily taken off or replaced than any heretofore made, and which, at the same time, when removed, shall give free and full access both to the valve and its seat so uncovered, and also removable, and to the interior parts of the adjacent pipes or other connections for the purpose of convenient inspection, repairing, cleansing, or removing obstructing objects from the valves or pipes.

To this end it consists, mainly, in, first, a detached curved portion of pipe, which incloses and covers the valve, and also the valve-seat, holding each in its proper place and permitting and guiding the proper movements of the valve; second, an improvement in the form and means of securing the screw-clamping bail for holding the valve-cover in position.

It also consists in certain other minor details of construction, as hereinafter shown and described.

In the accompanying drawings, Figure 1^a is a perspective view, showing my invention used as a blow-off or mud valve, parts being broken away to show also the internal structure. Fig. 1 is a perspective view of a modification, being a pump-barrel, C, with a projecting lug, C', for the induction-pipe *n* below, and valve-seat B and my removable valve-cover A above the lug, the cover and valve-seat being held in place by my pivoted swinging bail D and set-screw D'. Fig. 2 is a perspective view of the bail detached. Fig. 3 is another modification like Fig. 1, except the parts are held together by pivoted headed bolts secured in projecting lugs. Fig. 4 shows one of these bolts detached. Fig. 5 is a modification which shows a side elevation of a plunger pump-barrel with two valve-covers, one for the induction and one for the eduction valve. Figs. 6 and 7 show vertical central sections of modifications of the

valve-cover adapted to receive check-valves, the modification being only in placing the boss A' inside of the cover and omitting the same on the outside, all the bottom portion of the cover or valve-case and valve-seat being the same as those used in the forms shown in Fig. 1^a, 1, 3, 5, 9, 10, and 11. Fig. 8 is a horizontal cross-section of the valve-cover on line *xx* of Figs. 6 and 7, and through the guide-wing, and cover of Fig. 1^a, showing four inwardly-projecting guide-wings and the bottom inturned flange as used in all the forms of the valve-case shown, except that in Fig. 12. Fig. 9 shows a side elevation of the structure modified as a safety-valve. Fig. 10 is a modification which shows a side elevation of the valve-cover used as a throttle-valve. Fig. 11 is a side elevation of the structure shown in Fig. 1^a. Fig. 12 is a vertical central section of a modified valve-cover with a round leather disk suction-valve for cold water or liquids. Fig. 13 is a top view of this leather disk-valve detached. Fig. 14 is a modification which shows the application of my improved clamping-bail to holding round convex-topped valve-covers of a well-known form of plunger force-pumps.

The same letters refer to the same parts in the figures and to equivalent parts where modifications are shown.

Usually the curved elbow-shaped valve-cover A is made of such length that its ends are cut at right angles to each other, and so that the bearing-faces C' C'' are at right angles, though they may be more or less than this when desirable. The cover A is preferably made circular in cross-section, and at the end which receives the valve is formed with an inturned flange, A⁵, from which three or more inwardly-extending wings, A'', extend upwardly or inwardly from the end, and which serve as guides for the valve in its working up and down, being bored out so that the valve fits loosely therein, and, when desirable, having projecting lugs A''' to limit the upward movement or lift of the valve. Thus the flanges or wings A'' and stops A''' prevent side movement of the valve and limit its upward movement. These several parts are all cast solid with the external shell, A, and have

the advantage of being all bored out and the end faced upon one center and at one chucking in the lathe.

The flange or annular disk B has an inwardly-projecting hub or circular flange, B', which forms the valve-seat proper. The part B' is made to fit loosely and removably within the inturred flange A⁵, while the part B bears against the end of the valve-cover A, there being a suitable packing-gasket, O, introduced to prevent leakage, and also thin packing between B and C'' and between A and C'. For this packing I prefer to use thin rubber with thin tin or lead foil upon one of its surfaces. The foil adheres to the rubber, but not to the metal upon the other side, so that the valve-cover and valve-seat can always be removed easily without tearing the rubber by its adhesion, while its elasticity, with the pliability of its foil coating, always gives a perfectly-tight joint under pressure. In the broken section in Fig. 1^a is shown this packing O, composed of rubber and foil, the foil O' being partly broken away to show the rubber O''. Thus constructed the valve-cover A and valve-seat B only require firm pressure applied to the outer center of the cover A, perpendicularly thereto, to hold all the parts firmly in place with liquid and fluid tight joints, while a release of that one pressure releases all the parts.

The second part of my invention relates to convenient, effectual, and economical means of applying that pressure to the removable valve-cover; and the simplest plan consists of an improved form of screw-clamping bail, as shown in the several figures of the drawings.

The bail consists of a well-known form, except that in the old form the ends have inturred square lugs, which hitch under a projecting flange provided for that purpose, and when loosened have to be taken clear off, and are always liable to be dropped or tumble into wells, mines, deep water, or other inaccessible places over which they are used, and then require new ones to be made before the pump can be started again. My improvement in this bail consists in, first, making the lugs D'' round or cylindrical instead of square; second, in providing round shallow holes instead of a projecting flange for the reception of the lugs D''; and, third, in making the bail D wider than required by the length of one of the lugs D'', then, after it is otherwise finished, placing it in position and bending or closing it in until both lugs are permanently secured in the holes, when it cannot fall off nor become loose, and when a single turn of the clamping-screw D' tightens the valve-cover A or loosens it, allowing the bail D to swing down out of the way, so that the cover, valve, and valve-seat may all be removed and separated from their positions and from each other and be replaced with equal facility. When two valve-covers are used close together, as shown in Fig. 5, a single bail D, pivoted half-way between them, may hold both covers in place by using a short

bar or arch reaching from one cover to the other, and upon which the clamping-screw D' may press centrally.

Fig. 3 shows a modification in the means of securing the valve-cover in place, being the use of two pivot-headed bolts, D, secured between projecting lugs upon C'' by pivots D'', while the other end catches in slotted lugs *a*, cast upon the sides of cover A. This form of bolt is well known in the arts, and is not presented as new. Fig. 7 shows a hollow boss, A', on the inside of the valve-cover A, for a guide for the valve-stem *f*, while in Figs. 9, 10, and 11 this boss A' is placed upon the outside surface of A, the valve-stem *f* passing through it, and being provided with a stuffing-box, *f*'. In Fig. 10 the valve-stem *f* is provided with a hand-wheel, *h*, and otherwise fitted up just like the well-known form of a throttle or globe valve, the position of the valve and internal chambers being indicated by dotted lines. In Fig. 9 the screw-thread is left off the valve-stem *f*, and a safety-valve lever, *l*, and weight are attached instead of the hand-wheel in Fig. 10. In Fig. 11 is shown a hand-lever, *l*, similarly attached for completing the structure as a blow-off or mud valve, as it, by loosening a single set-screw D', gives a free direct opening, the full size of the pipes right into the mud-drum, or other part to which it is attached, for the convenient and certain inspection and sure removal of all accumulated mud and other foreign matter by direct use of scrapers, swabs, or hose. It is necessary that the valve-stem should move up and down in a straight line. In order for it to do that, it becomes necessary for the pivoted ends of the levers in Figs. 11 and 9 to have movement toward and from the valve-stem to accommodate itself to the direct and varying diagonal directions assumed by the lever connecting them. To provide for this movement, which is indicated by dotted lines in Fig. 11, I have invented a modified form of the pivoted bail, which is simply a round rod of metal bent in the form shown in the detached view in Fig. 11, and passed through an eye-hole in the end of the lever *l*, and the bottom lugs, D'', closed into holes provided for them in the sides of the casting, which gives the bail a broad supporting-base and permits free motion only in the direction required. This form of this bail is also equally well adapted to lever hand-pumps where the valve or sucker rod works through a stuffing-box or other fixed guide.

The valve shown in Figs. 12 and 13 consists of a circular disk of leather or of gum packing, B'', (substituted in place of B in the other figures,) with a circular central flap stiffened by a block, B''', in a well-known form. The periphery of the flexible disk B'' serves as a packing in the joint between A and C'', and at the same time holds the valve B''' centrally over the induction-port, the flexible uncut connection of B'' and B''' serving as a hinge for the latter.

This valve-cover is also especially well adapted for a ball-valve by simply dressing the under side of the stop-lugs A''' to a curve to fit the ball when lifted. Still other forms of valves and other positions or locations and connections in which to use my valve-cover and pivoted bail will readily suggest themselves from the foregoing to any skilled machinist without departing from the spirit or scope of my invention.

The particular kind of valve used with the valve-cover and the particular locations where my valve-cover and bail may be used not being essential parts of my invention, I do not limit myself to the forms and locations here shown. The elbow-shaped valve-cover may, in some places, be much less than a quarter of a circle—may, in fact, be reduced to a hollow wedge, and perform the same functions in the same way; or it may be a half-circle and constitute a return-bend, with or without a valve; and as a return-bend with my pivoted bail it is especially valuable and well adapted where two or a tier of pipes have cast or other connections of the tier—as, for example, in beer-coolers of the Baudelot type—it being necessary that pipes for that and other uses in the art shall be made with removable plugs or connections, so that the accumulated slime, &c., can frequently be scraped and cleaned from the whole interior surface.

What I claim as my invention, and desire to secure by Letters Patent, is—

1. The combination, with a removable valve-cover, of a swinging clamp, substantially as shown and described, for holding the cover in place, as set forth.

2. The combination, with a removable hollow valve-cover, of a clamping-bail, substantially as described.

3. The removable hollow open-ended valve-cover A, in combination with its two hollow end bearing-seats, C' C'', formed at the same angle to each other as that of the ends of the valve-cover, substantially as described.

4. The screw-clamping bail D, having inwardly-projecting cylindrical-shaped lugs D'', in combination with a connecting-base provided with round holes corresponding with said lugs, and into which the lugs are forced and permanently secured by bending the bail inwardly, as described, whereby the disconnection or loss of the bail is prevented and a free swinging motion thereof permitted, as and for the purpose described.

5. The removable valve-cover A, provided with inturned flange A⁵ and valve-guiding wings A'', in combination with a corresponding removable valve provided with a stem and valve-seat, substantially as set forth.

6. The removable valve-cover A, provided with the inturned flange A⁵ and valve-guiding wings A'', having valve-stops A''', inclosing a valve and a valve-seat, in combination with the end fitting-connections, C' C'', substantially as set forth.

7. In combination with the removable cover A, an inclosed valve, a valve-seat, B, end fitting-connections, C' C'', pivoted swinging bail D, and set-screw D', substantially as set forth.

8. The combination of the removable hollow curved connecting-section A, the pivoted bail D, having set-screw D', and end connections, C' C'', whereby a continuous curved open-connection is formed through all the ports, for the purpose set forth.

9. The combination of the removable valve-cover A, the swinging clamping-bail D, the supporting-base C'', and the adjacent connection C', as set forth.

10. The removable cover A, provided with inturned flange A⁵ and valve-guiding wings A'', in combination with a corresponding removable valve provided with a stem and valve-seat, and means for operating said valve, substantially as described.

EDWIN E. CARTER.

Witnesses:

F. T. GUIHER,

JOHN M. WALLACE.